

COTAS SIN TOLERANCIA/DIMS WITHOUT TOLERANCE (mm)		
Más de/Bigger than	hasta/up to	Tolerancia/Tolerance
0,5	6	±0,1
6	30	±0,2
30	120	±0,3
120	315	±0,5
315	1000	±0,8

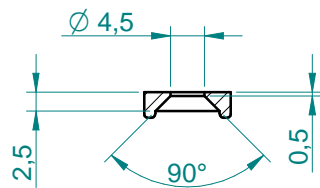
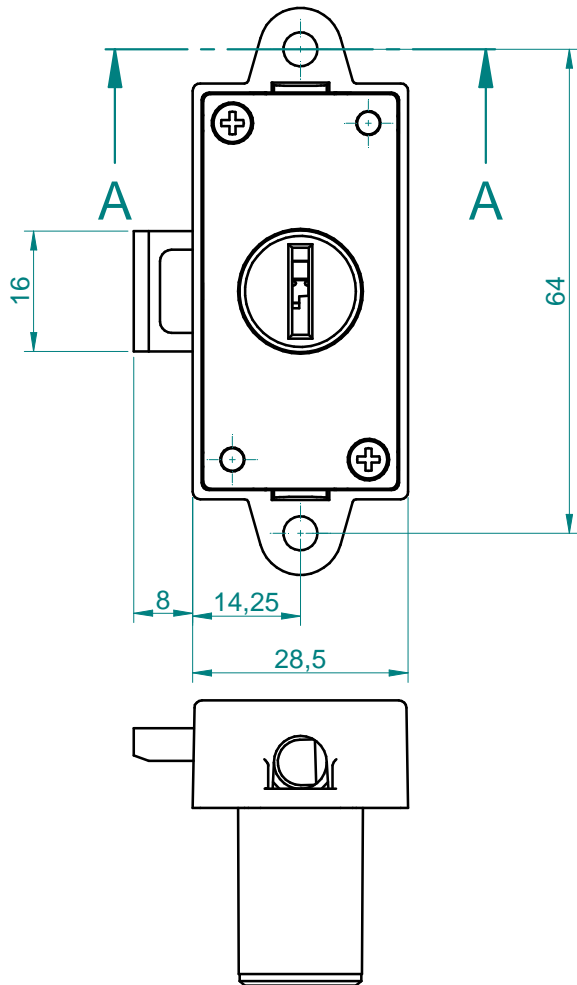
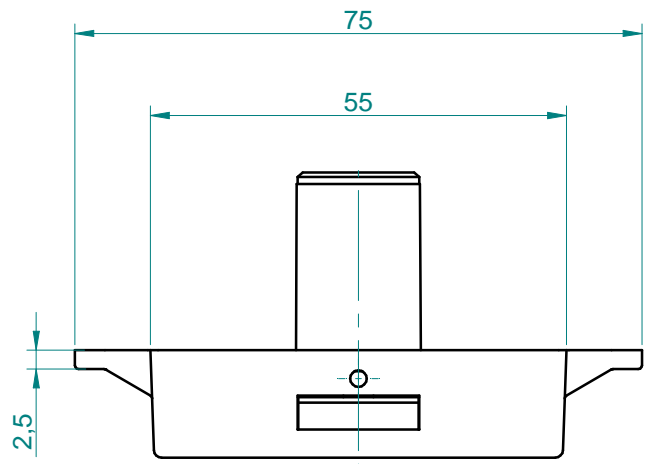
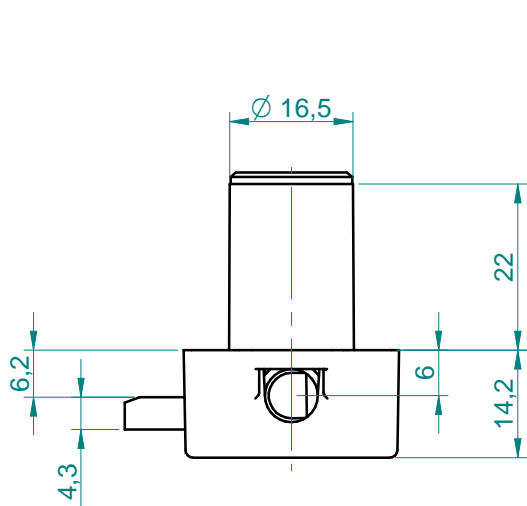

CORTE A-A

GIRO 180° SENTIDO HORARIO

Date	Name	Date	Name	Index	Modification		
Drawn 25/01/2005	JON						
Checked							
This document and its content is property of Ojmar and for strictly confidential use. Not to be copied or distributed to third parties without the permission of Ojmar.					Material		
					Reference		Edition
Part name CRDA. 968 Ø16,5 E-15 DERECHA					2968.001	01	1:1